

EZ Series LM

Console Water Source Heat Pump Replaces McQuay and Singer

Islandaire "The Perfect Fit" units are designed to exactly replace the original, existing chassis! No field modification kits or builder renovations are required. Islandaire units are designed for optimal efficiency and reliability. This unit has the ability to have the piping and the controls "reversed" in the field. If you order the wrong side for piping and controls, no problem. Just reverse them in the field saving time and money. This appliance is intended for new construction or replacement of McQuay and Singer LM water source heat pumps. Please confirm that the electrical rating of this appliance matches the electrical supply available before beginning installation.

Features on the EZ Series LM:

- Right hand piped, left hand controls, but can be factory or field reversed
- Superior energy efficient ratios (EER)
- High efficiency coaxial condenser coil
- High efficiency evaporator coil
- Commercial duty construction with heavy gauge galvanized steel
- High pressure protection
- Compressor and water circuit freeze protection
- Refrigerant circuit access ports

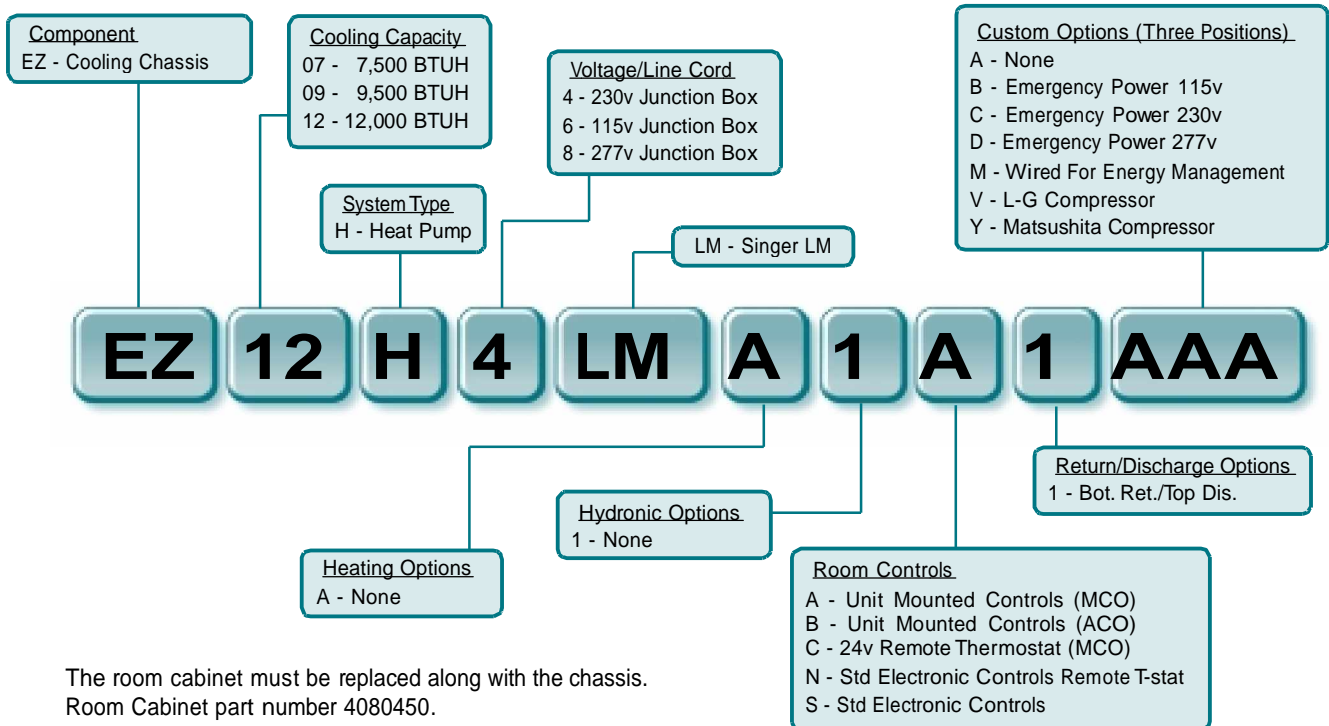
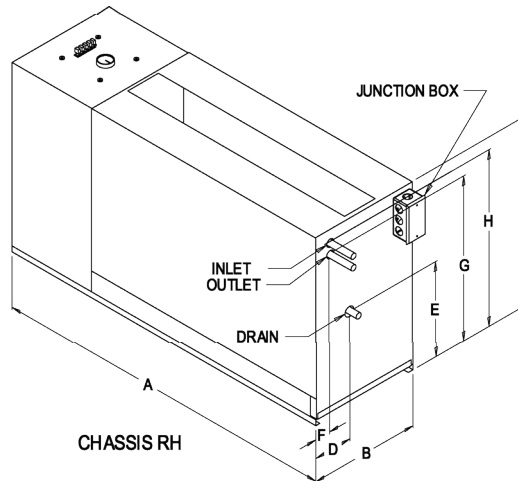

EZ Series LM



MODELS

	EZ07				EZ09				EZ12				EZ15			EZ18		
VOLTS	115	230	208	277	115	230	208	277	115	230	208	277	—	—	—	—	—	—
BTUH COOLING	8,100	8,100	7,900	8,100	9,300	9,300	9,100	9,300	12,200	12,200	12,000	12,200	—	—	—	—	—	—
AMPS COOLING	6.3	3.4	3.5	3.2	8.8	4.4	4.5	3.8	10.3	6.2	6.5	5.0	—	—	—	—	—	—
WATTS COOLING	575	575	535	575	691	691	661	691	897	897	867	897	—	—	—	—	—	—
EER	14.0	14.0	14.0	14.0	13.5	13.5	13.5	13.5	13.6	13.6	13.6	13.6	—	—	—	—	—	—
CFM HIGH	420	420	410	420	420	420	410	420	460	460	450	460	—	—	—	—	—	—
CFM LOW	280	280	270	280	280	280	270	280	320	320	310	320	—	—	—	—	—	—
BTUH HEATING	9,600	9,600	9,580	9,600	12,000	12,000	11,800	12,000	15,000	15,000	14,800	15,000	—	—	—	—	—	—
WATTS HEATING	610	610	600	610	771	771	751	771	953	953	933	953	—	—	—	—	—	—
C.O.P.	4.6	4.6	4.6	4.6	4.5	4.5	4.5	4.5	4.6	4.6	4.6	4.6	—	—	—	—	—	—
G.P.M.	2.0	2.0	2.0	2.0	2.0	2.0	2.0	2.0	3.0	3.0	3.0	3.0	—	—	—	—	—	—

Note: Data based on ARI Standard 320

Cooling - Entering Air - 80 deg. F DB \67 DEG. F WB

- Entering Water - 85 deg. F

Heating - Entering Air - 70 deg. F DB

- Entering Water - 70 deg. F

Line Voltage	Maximum Amperage	Wall Socket Configuration	Receptacle Number
115	16		NEMA 5-20R
208/230	16		NEMA 6-20R
208/230	24		NEMA 6-30R
277	16		
208/230	12		NEMA 6-15R

