

EZ SERIES

KF

Replacement for

Islandaire EZ Series KF is "The Perfect Fit" replacement for the Remington, Singer and McQuay models of K units. Our commercial duty construction with heavy gauge galvanized steel and superior components create an efficient reliable unit. "The Perfect Fit" design eliminates the need for any interior or exterior renovation. Use of the existing wall sleeve-cabinet and louver saves time and money, two very important factors in today's competitive environment! If the need does occur where the wall sleeve, sloped room cabinet and flat top room cabinet and/or louver needs to be replaced, we manufacture these accessories as well. T.O.D.C. is offered. If cooling section only is ordered a molex plug is provided.

FEATURES

- All Products Proudly Made in the U.S.A.
- UL listed products
- Superior Energy Efficiency Ratios (EERs)
- Commercial Duty Construction with Heavy Gauge Galvanized Steel
- Designed for "The Perfect Fit" replacement of existing sleeve opening
- Rotary and Reciprocating Compressors Available
- Emerson, General Electric, and MagneTek P.S.C. Evaporator and Condenser Motors Used
- High-Efficiency Refrigeration Coils Used to Provide Superior Heat Transfer
- Ranco Thermostats Provide Accurate, Dependable Temperature Sensing
- Units Available as Cooling only, Cooling with Electric Heat, Cooling with Hydronic Heat, or Heat Pumps
- Custom Options Available
- Available with State-of-the-Art Digital *Intellitemp™* Control System

Voltage/Line Cord	
1 - 115v 20 Amps	7 - 277v 20 Amps
2 - 230v 20 Amps	8 - 277v Junction Box
3 - 230v 30 Amps	9 - 230v 15 Amps
4 - 230v Junction Box	A - 208v 15 Amps
5 - 115v 15 Amps	B - 208v 20 Amps
6 - 115v Junction Box	C - 208v 30 Amps
	D - 208v Junction Box

Cooling Capacity	
07 - 7,500 BTUH	
09 - 9,500 BTUH	
12 - 12,000 BTUH	
15 - 15,000 BTUH	

Component
EZ - Cooling Chassis
HS - Heat Section

System Type
E - Std. Chassis
H - Heat Pump

Model Type
KF - Remington, Singer, McQuay

Return/Discharge Options
1 - Bot. Ret./Top Dis.
4 - Front Ret./Top Dis.
7 - Sloped Top

Identity Code
0 - Special
4 - Standard

Functional Options		Functional Option Codes	
A- None	B- Motorized Damper	A- A	M- BDE
C- Fan Cycle Switch	D- Indoor Freeze Protect	B- B	N- BDEF
E- Winter Operation	F- Hi Pressure Cut Out	C- BC	P- BDF
		D- BCD	Q- BE
		E- BCDE	R- BEF
		F- BCDEF	S- BF
		G- BCDF	T- C
		H- BCE	U- CD
		J- BCEF	V- CDE
		K- BCF	W- CDEF
		L- BD	X- CDF
			Y- CE
			Z- CEF
			1- CF
			2- D
			3- DE
			4- DEF
			5- DF
			6- E
			7- EF
			8- F

*Codes are entered into model number.



Heating Options
A - None Cooling Only
B - 2.5 Kw Elec. Heat (208V-277V)
C - 3.6 Kw Elec. Heat (208V-277V)
D - 4.2 Kw Elec. Heat (208V-277V)
E - 5.0 Kw Elec. Heat (230V-277V)
F - Hyd. Fan Cycle W/T-Stat (115V-277V)
G - Hyd. with Aquastat (115V-277V)
H - Hyd. W/2.5 Kw B.U. Heat (208V-277V)
I - Hyd. W/3.6 Kw B.U. Heat (208V-277V)

Hydronic Options
1 - None
2 - 24v NC Valve
3 - 115v NC Valve
4 - 230v NC Valve
5 - 277v NC Valve
6 - 24v NO Valve
7 - 115v NO Valve
8 - 230v NO Valve
9 - 277v NO Valve

Room Controls
A - Unit Mounted Controls (MCO)
B - Unit Mounted Controls (ACO)
C - 24v Remote Thermostat
F - Master
G - Slave
M - Intellitemp™ Controls (Remote T-Stat)
N - Standard Electronic Controls (Remote T-Stat)
S - Digital Controls (Unit Mounted)
T - Intellitemp™ Controls (Unit Mounted)

Power Mgt. Options		Power Mgt. Codes	
A- None	B- Power Disconnect	A- A	N- BG
C- Energy Mgt. N/O	D- Energy Mgt. N/C	B- B	P- C
E- Emerg. Power 115V	F- Emerg. Power 230V	C- BC	Q- CE
G- Emerg. Power 277V		D- BCD	R- CF
		E- BCF	S- CG
		F- BCG	T- D
		G- BD	U- DE
		H- BDE	V- DF
		J- BDF	W- DG
		K- BDG	X- E
		L- BE	Y- F
		M- BF	Z- G

*Codes are entered into model number.



Wall sleeve-cabinets
and exterior louvers
available.
See accessories on pages 70-71.

MODELS

	EZ07				EZ09				EZ12				EZ15			EZ18		
	115	230	208	277	115	230	208	277	115	230	208	277	230	208	277	230	208	277
BTUH COOLING	7,500	7,500	7,300	7,500	9,500	9,500	9,300	9,500	12,200	12,200	12,000	12,200	15,000	14,800	15,000	16,900	16,700	16,900
AMPS	5.7	2.9	3.1	2.3	7.4	3.7	4.0	3.1	10.1	5.1	5.5	4.2	6.8	7.5	5.8	8.1	8.8	6.6
WATTS COOLING	660	658	640	647	845	850	830	848	1135	1140	1123	1143	1572	1557	1614	1779	1797	1790
EER	11.4	11.4	11.4	11.6	11.2	11.2	11.2	11.2	10.7	10.7	10.7	10.7	9.6	9.6	9.6	9.5	9.5	9.5
CFM HIGH	340	340	320	340	400	400	380	400	400	400	380	400	460	440	460	460	440	460
CFM LOW	260	260	240	260	260	260	240	260	340	340	320	340	340	320	340	340	320	340
BTUH HEATING	N/A	7,100	6,900	7,100	N/A	9,300	9,100	9,300	N/A	11,400	11,200	11,400	14,300	14,200	14,800	N/A	N/A	N/A
WATTS HEATING	N/A	740	720	740	N/A	901	780	871	N/A	1014	979	979	1290	1365	1380	N/A	N/A	N/A
C.O.P.	N/A	2.9	2.9	2.9	N/A	3.03	2.9	3.13	N/A	3.30	2.9	3.41	3.25	2.7	3.14	N/A	N/A	N/A

Heating Option	Voltage (1)	Wattage	B.T.U.s (2)	Amps (3)
B	208	2,050	7,000	10.46
	230	2,500	8,535	11.47
	277	2,500	8,535	9.63
C	208	2,950	10,070	14.78
	230	3,600	12,290	16.25
	277	3,600	12,290	13.60
D	208	3,433	11,720	17.10
	230	4,200	14,330	18.86
	277	4,200	14,330	15.76
E	208	4,100	14,000	20.31
	230	5,000	17,070	22.34
	277	5,000	17,070	18.65

(1) Voltage is Single Phase, Alternating Current and R.M.S. (2) Heating Capacity (B.T.U./Hr.) based on indoor blower motor and heating elements. (3) Amp values are a combination of indoor blower motor and heating elements.

Heating capacities specified in accordance with ARI standard 380-82 at conditions of 47 F WB outdoor and 70 F DB/60 F WB indoor. Wattage, Amperage, COP, EER listings include compressor, evaporator motor and condenser fan motor. Cooling capacities specified in accordance with ARI standard 380-82 at conditions of 95 F DB/75 F WB outdoor and 80 F DB/67 F WB indoor.

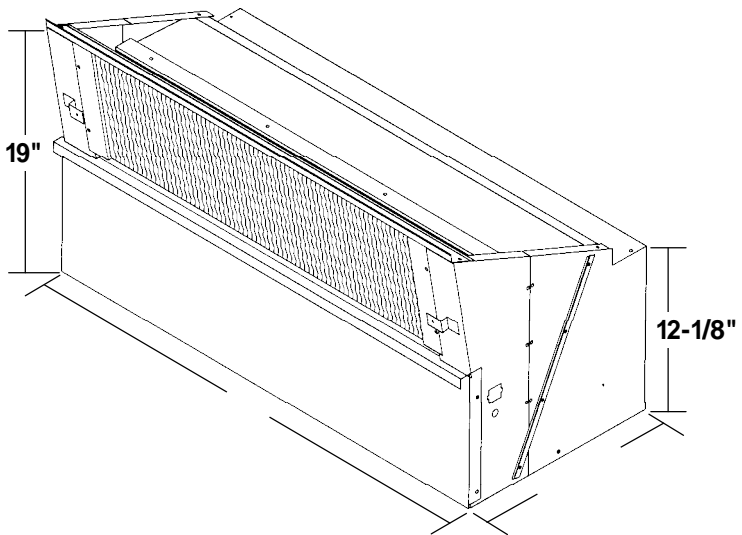

Line Voltage	Maximum Amperage	Wall Socket Configuration	Receptacle Number	Electrical Heat Options
115	16		NEMA 5-20R	N/A
208/230	12		NEMA 6-15R	N/A
208/230	16		NEMA 6-20R	2.5 - 3.6
208/230	24		NEMA 6-30R	4.2 - 5.0
277	16		NEMA 7-20R	2.5 - 5.0

